

VIPP906

# Bathroom Tap

INSTALLATION INSTRUCTIONS

## **ENGLISH – INSTALLATION GUIDE**

- Make sure to follow the local construction and plumbing regulations when installing the tap. Contact a professional, if you are in doubt
- Make sure that the water is switched off during the installation
- Check regularly for any leakage
- Do not tighten the fittings too hard, as this might damage the hoses.

## **DANSK – MONTERINGSVEJLEDNING**

- Følg altid de gældende lokale regler for byggeri og VVS-arbejde når armaturet monteres. Hvis du er i tvivl, så kontakt en fagperson.
- Sørg for at der er slukket for vandet under montagen af armaturet
- Undersøg regelmæssigt om der er lækage fra armaturet
- Spænd ikke slangernes fittings for hårdt da dette kan beskadige slangerne.

## **SVENSKA – INSTALLATIONS MANUAL**

- Var noga med att följa de lokala föreskrifterna för byggnad och VVS när du installerar kranen. Kontakta en professionell om du är osäker.
- Se till att vattnet är avstängt under installationen.
- Kontrollera regelbundet eventuellt läckage.
- Dra inte åt beslagen för hårt, eftersom det kan skada slangarna.

## **NORSK – INSTALLASJONSVEILEDNING**

- Sørg for å følge de lokale bygge- og rørleggerforskriftene når du installerer kranen. Kontakt en profesjonell hvis du er i tvil
- Forsikre deg om at vanntilførselen er koblet fra under installasjon
- Se etter lekkasje regelmessig
- Stram ikke armaturen for hardt, da dette kan skade slangene.

## **DEUTSCH – INSTALLATIONSLEITFADEN**

- Bei der Installation der Armatur auf die Einhaltung der lokalen Bau- und Sanitärvorschriften achten. Im Zweifelsfall einen Fachmann konsultieren
- Sicherstellen, dass das Wasser während der Installation abgestellt ist
- Regelmäßige Dichtigkeitsprüfungen durchführen
- Die Verbindungsstücke nicht zu fest stellen, da hierdurch Schläuche beschädigt werden könnten.

## ESPAÑOL – GUÍA DE MONTAJE

- Asegúrese de que cumple la normativa local sobre construcción y fontanería durante el montaje del grifo. Póngase en contacto con un profesional si tiene dudas
- Asegúrese de que el agua está cerrada durante el montaje
- Compruebe con regularidad que no hay fugas
- No apriete con demasiada fuerza los empalmes, ya que esto puede dañar las mangueras.

## FRANÇAIS – GUIDE D'INSTALLATION

- Lorsque vous installez le robinet, assurez-vous de respecter les réglementations locales relatives à la construction et la plomberie. En cas de doute, contactez un professionnel
- Assurez-vous que l'eau est coupée durant l'installation
- Vérifiez régulièrement l'absence de fuite
- Ne serrez pas trop les raccords, au risque d'endommager les tuyaux.

## 英文安装指南

- 安装水龙头时，必须遵守当地建筑和管道安装规范。如有疑问，请联系专业人员处理。
- 在安装过程中，请确保关闭水管。
- 请定期检查有无泄漏。
- 配件不得安装过紧，以免损坏软管。

## OPERATING CONDITIONS:

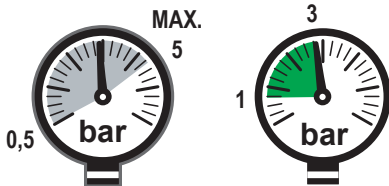

### Water pressure:

Min. operating pressure: 0,5 bar.  
Max. operating pressure: 5 bar.  
For optimal performance keep between 1 and 3 bar.

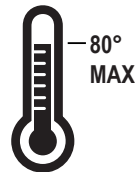

### Temperature:

Max. operating temperature:  
80 degree celsius.

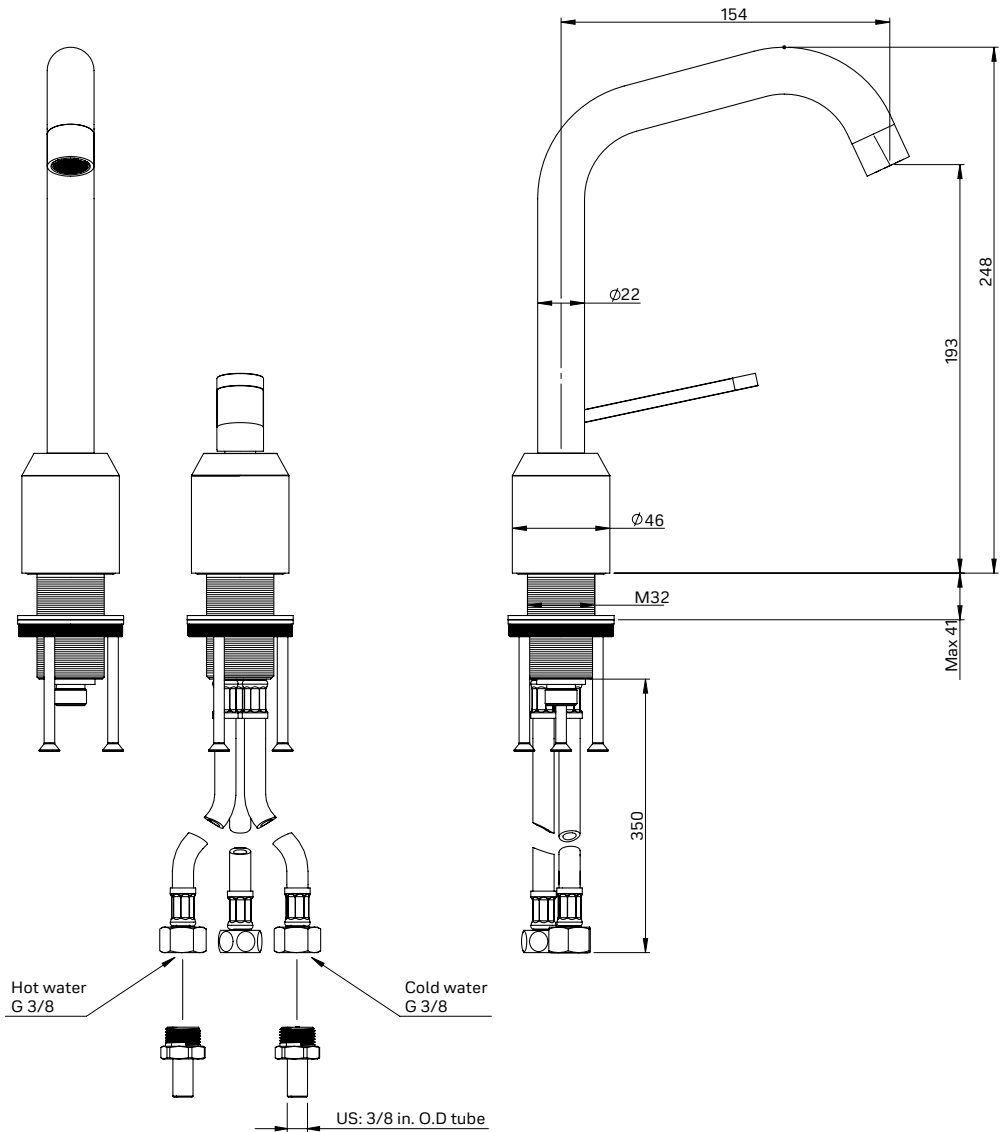

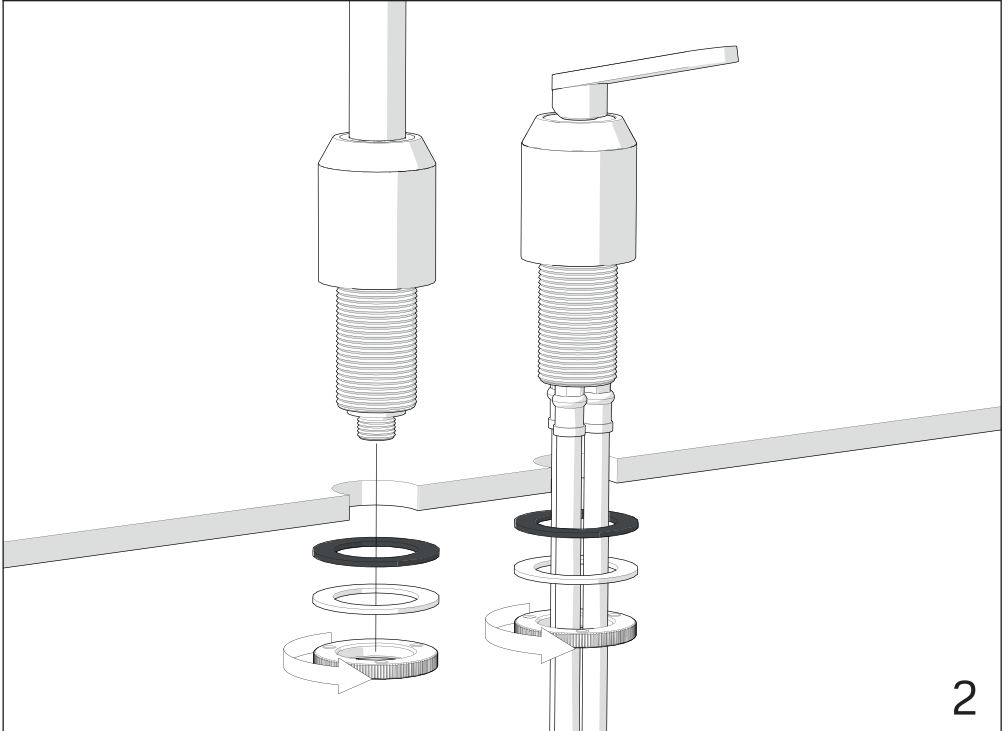
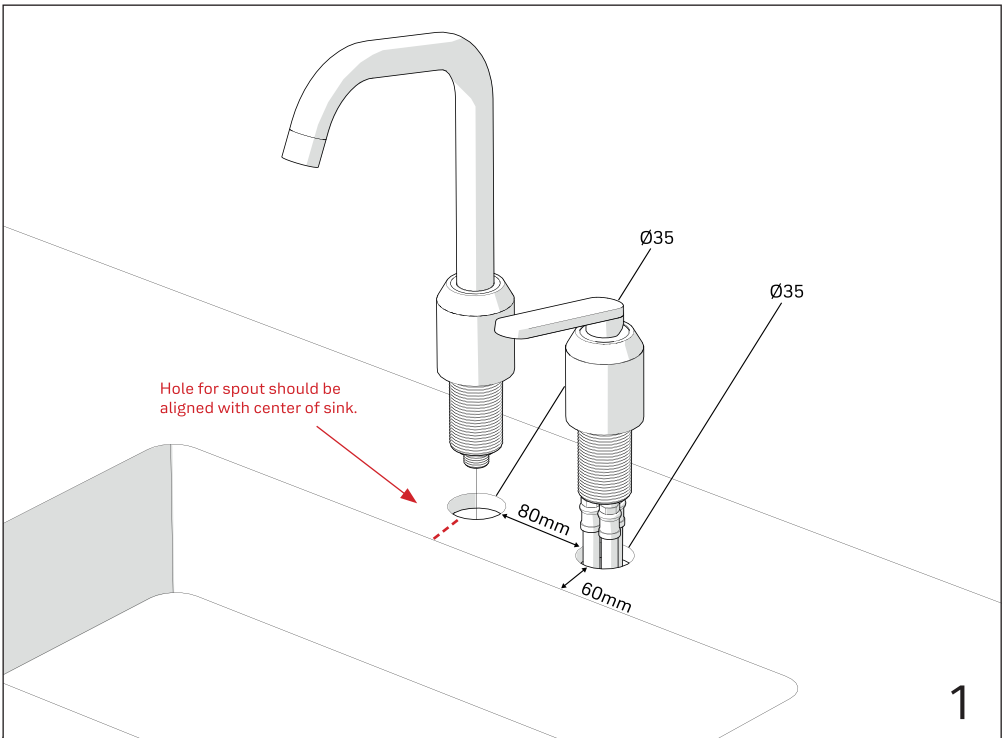

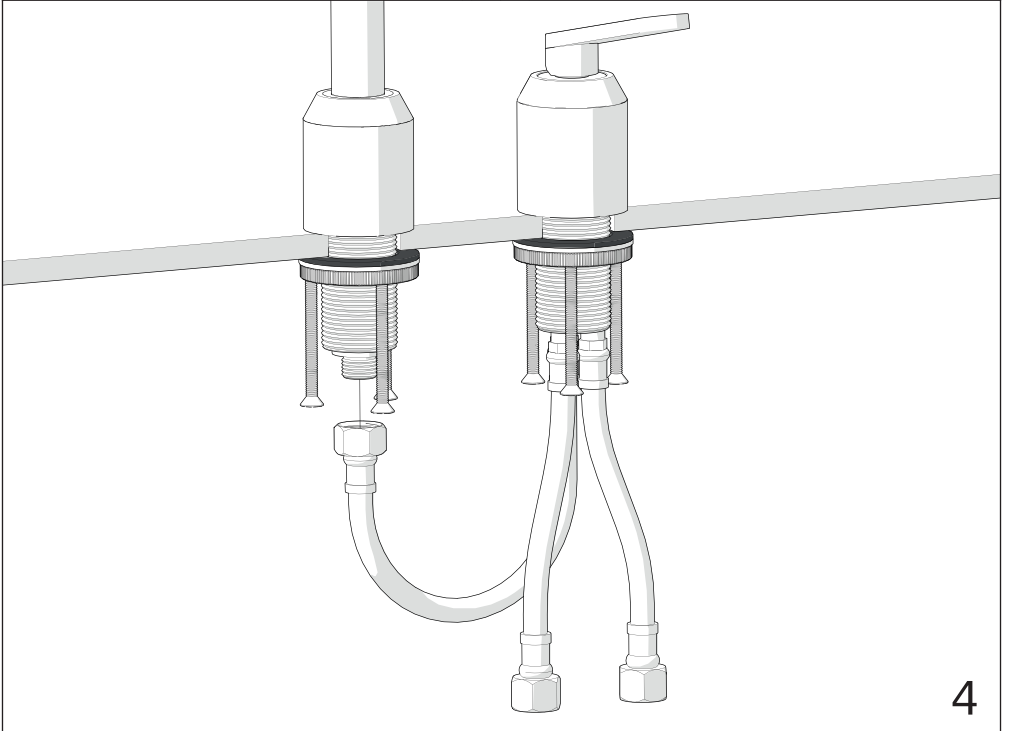
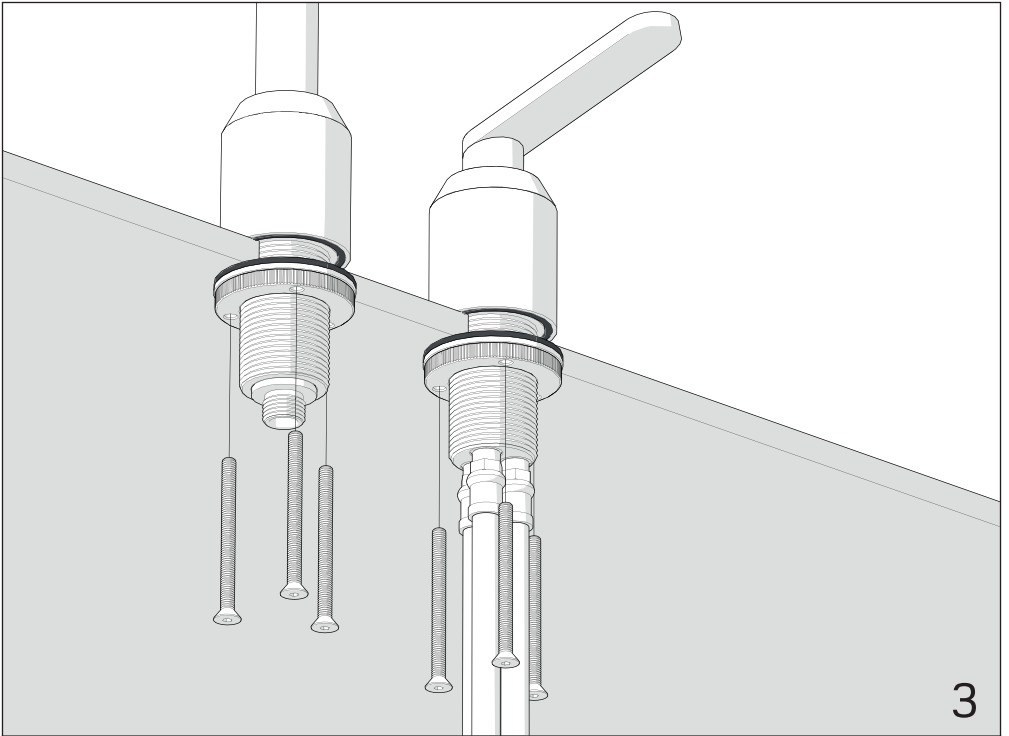

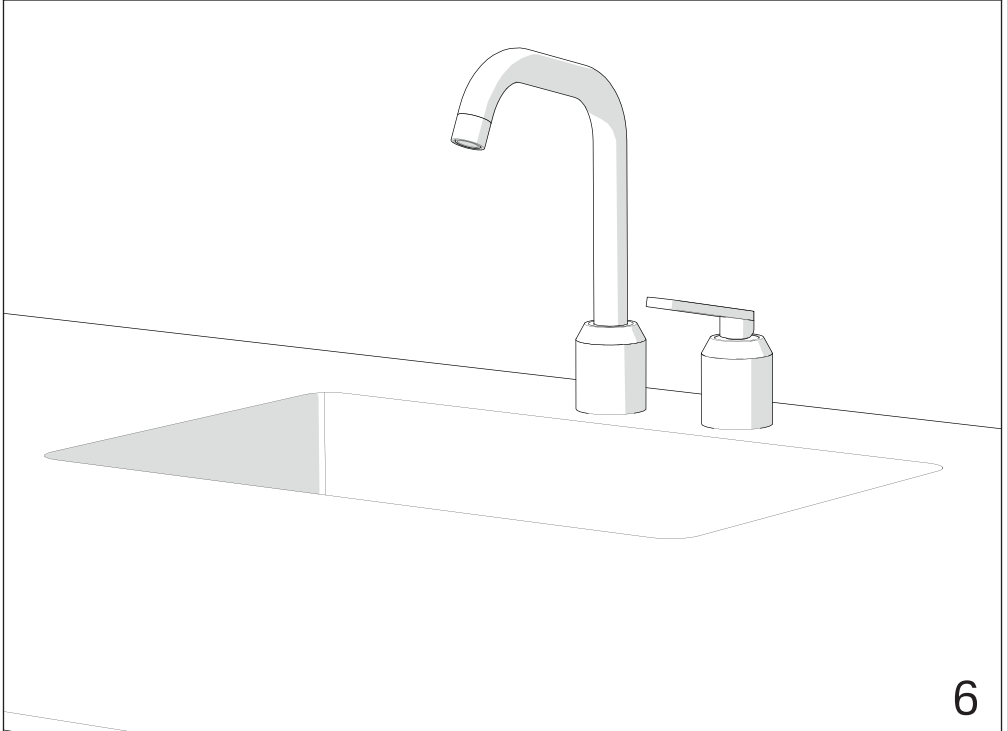
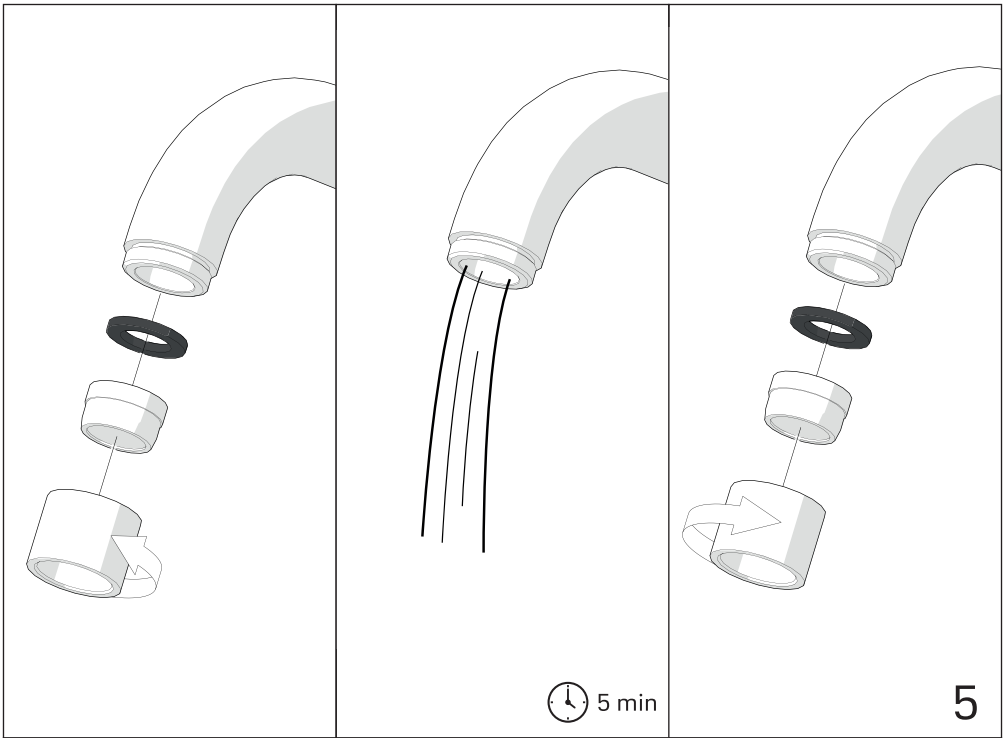

**CONTACT**

**Vipp**

Snorresgade 22 | 2300 Copenhagen S | Denmark  
+45 4588 8800 | info@vipp.com

**Vipp Concept Store and Kitchen Showroom**

Ny Østergade 34 | 1101 Copenhagen K | Denmark  
+45 4588 8815 | cph@vipp.com

**Vipp USA LLC Showroom**

39 Lispenard Street, 5th floor | New York, NY 10013 | USA  
+1 (917) 580 2148 | vippusa@vipp.com

vipp.com



**GODKENDT  
TIL DRIKKEVAND**



20046



SC1016-16 | SP Certification 1002  
Inspected by DTI



NSF-61/9  
ASME A112.18.1/CSA B125.1



Certified by  
NSF International  
Flow rate:  
4,5 L/min (1,2 gpm)