

CHOICE LUMINAIRE OH

warmDIM

NC50-0

NC50-2

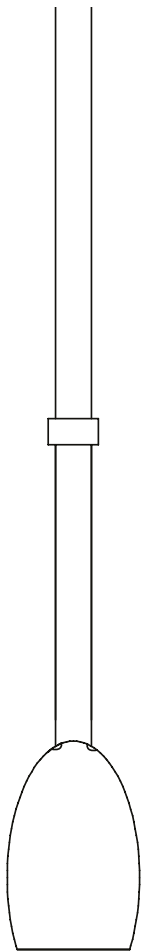

GRAU

01 ① ②

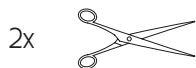
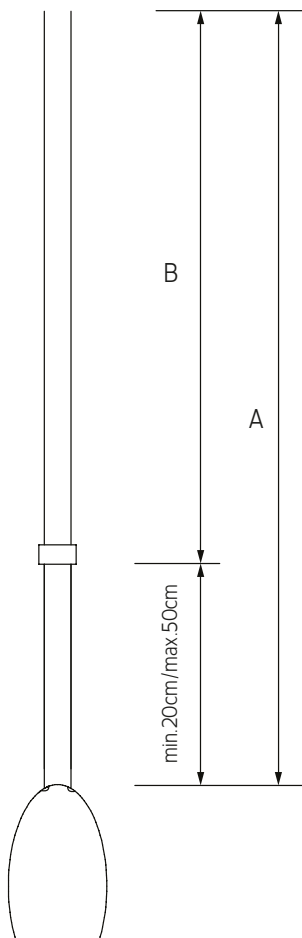

$$L = A + B$$

i ① ②

01

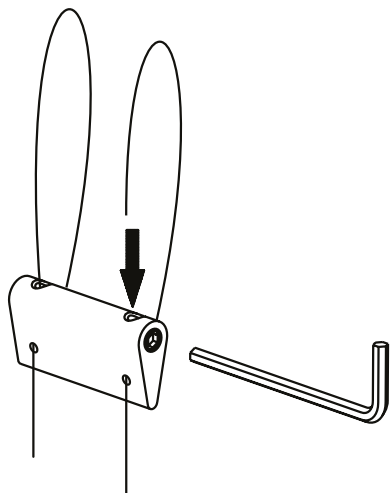

Schraube festziehen!
Tighten the screw!
Serrer la vis!

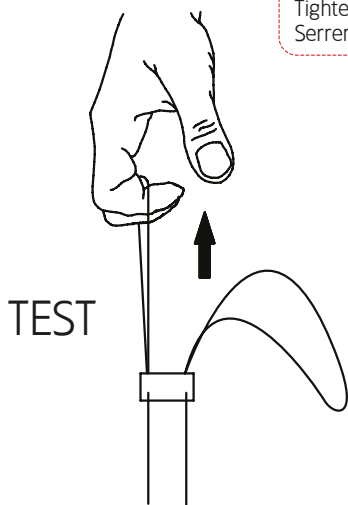

Montageanleitung • Assembly instructions

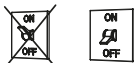

Unbedingt beachten!

Bitte beachten Sie, dass vor Verbindung der Kabel, die Stromversorgung auf der Primärseite getrennt ist, da sonst die LED Schaden nimmt!

Sollte der Konverter bereits ohne Leuchte angeschlossen worden sein oder war die Leuchte verpolt angeschlossen, dann trennen Sie bitte die Stromversorgung auf der Primärseite und warten Sie zwei Minuten, bevor Sie die Sekundärseite wieder anschließen!

Bei nicht beachten entfällt die Garantie!

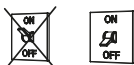

Important!

Before installing this product, ensure power is switched off.

If the converter has first been connected to the power supply, switch the power supply off and wait 2 minutes before connecting to the luminaire.

Failure to do so may damage the LED!!!

A failure to comply will result in a loss of guarantee!

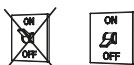

Attention!

Avant de brancher le luminaire, veuillez absolument vous assurer que le courant a été coupé, dans le cas contraire la platine LED subit des dommages.

Si le convertisseur a déjà été mis sous tension, veuillez couper le courant et attendre deux minutes avant de connecter le luminaire au convertisseur.

In cas de non respect de cette clause la garantie ne s'applique pas!

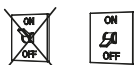

Attenzione!

Prima di collegare il prodotto alla presa di corrente assicurarsi che quest'ultima sia spenta. In caso contrario il LED potrebbe subire dei danni!

Se il convertitore è già stato collegato alla presa di corrente è necessario spegnere quest'ultima e aspettare 2 minuti prima di collegare nuovamente la lampada.

La garanzia decade in caso non si presti attenzione a tale avvertimento!



Montageanleitung • Assembly instructions

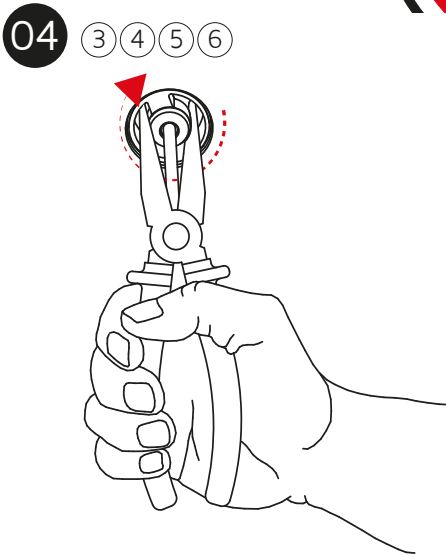
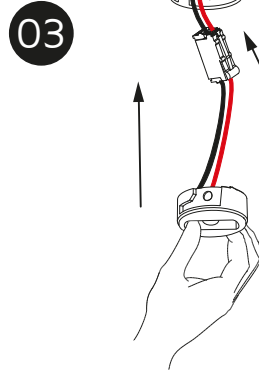
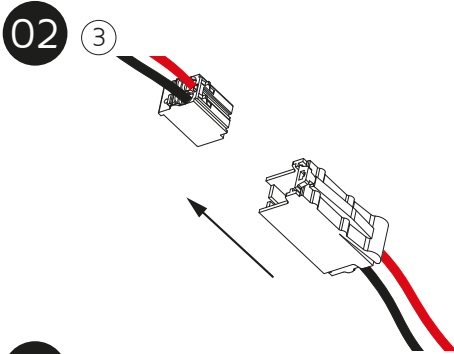

Über einen spürbaren Widerstand drehen.
Turn past resistance point.

Beim Einsetzen der Leuchte nicht drücken.
Do not push while inserting the bayonet adapter.

Nicht in die falsche Richtung drehen.
Do not turn in the wrong direction.

- = schwarz / black
+ = rot / red

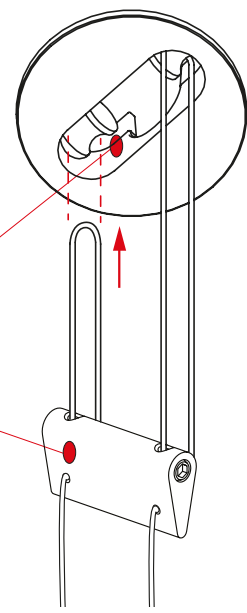

01 ⑥

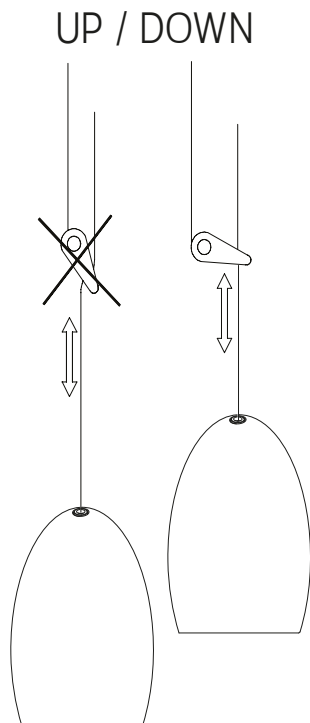

Achtung! • Attention!

Bitte die Leuchte im eingeschalteten Zustand weder anheben noch höhenverstellen, da durch Unterbrechung der Spannung die LED beschädigt wird.

Please do not raise the luminaire or adjust the wire length while it is switched on as the LED will be damaged if the voltage is interrupted.

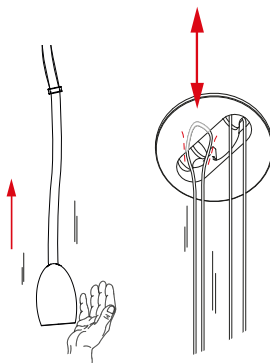

i ⑥

01

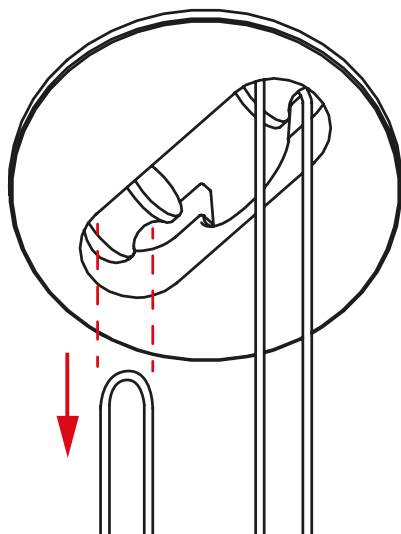

02



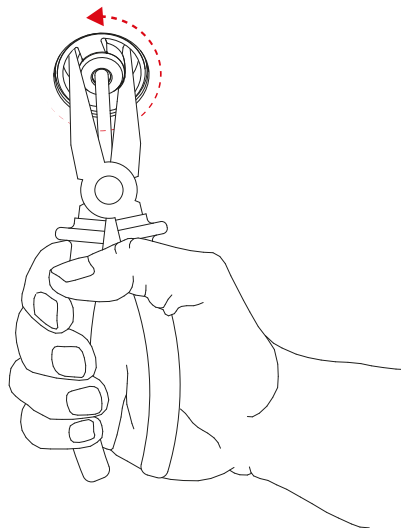

Über einen spürbaren Widerstand drehen.
Turn past resistance point.





DEUTSCH

- ① Die Ware muss vor Montage auf optische Fehler bzw. Kratzer überprüft werden. Mit der Montage erlischt der Reklamationsanspruch auf optische Mängel der Ware.
- ② Bitte lassen Sie die Montage von einem Elektrofachbetrieb durchführen.
- ③ Auf die Polung der Kabellitzen achten!
Sollte die Leuchte falsch gepolt angeschlossen worden sein, müssen Sie vor der Korrektur den Strom ausschalten! Ansonsten kann die Leuchte beschädigt werden!
- ④ Oberflächenschutz:
Alle polierten, lackierten oder galvanisch veredelten Oberflächen sind vor Belastungen jeglicher Art zu schützen – insbesondere alle Kupferteile, welche nur mit einem unsichtbaren Anlaufschutz versehen sind.
- ⑤ Bitte die Leuchte ausschließlich mit einem trockenen Tuch reinigen. Wir empfehlen Microfasertücher für empfindliche Oberflächen. Das Reinigen muss in abgekühltem Zustand erfolgen.
- ⑥ Bitte beachten Sie, dass bei häufiger Höhenverstellung der Leuchte die Seile verschleifen können. Dies sollte von Zeit zu Zeit überprüft werden.

CHOICE LUMINAIRE OH	
	Schutzklasse 3
	Dieses Produkt enthält eine Lichtquelle der Energieeffizienzklasse G. Diese kann nur vom Hersteller ausgetauscht werden.
	SEC 500mA / 11W
	73/23/EWG 89/336/EWG





GARANTIE:

Sie haben ein hochwertiges Produkt erworben, welches mit Sorgfalt produziert und verpackt worden ist. Sollten Sie dennoch einmal Grund zur Beanstandung haben, wenden Sie sich bitte ausschließlich an Ihren Händler. Geben Sie bitte die auf der letzten Seite genannte Endkontrollnummer bei Ihrer Reklamation an. Ihre Reklamation wird bei uns im Hause umgehend bearbeitet. Bitte haben Sie Verständnis, dass eine Garantie unsererseits nur bei sachgemäßer Montage übernommen werden kann - wir empfehlen daher Fachbetriebe.



ENGLISH

- ① The products must be checked for visual defects, and/or scratches, prior to assembly. Once the product has been assembled, the right for a customer to make a complaint due to visual defects expires.
- ② Please have a qualified electrical specialist carry out the installation.
- ③ Pay attention to the polarity of the cable strands!
If the polarity of the suspension is reversed, please disconnect the main power before correction, in order to avoid any technical damages.
- ④ Surface protection:
All polished, lacquered or galvanised surfaces have to be protected against all types of stresses – especially all copper parts, as they are only provided with an invisible protection against tarnishing.
- ⑤ Please clean the lamp with a dry cloth. We recommend microfibre cloths for sensitive surfaces. Only clean the lamp after it has cooled down.
- ⑥ Please take a note that the cable will show wear with frequent height adjustment of the lamp. This should be checked from time to time.

CHOICE LUMINAIRE OH	
	Protection class 3
	This product contains a light source of energy efficiency class G. The LEDs can be replaced by the producer only.
	SEC 500mA / 11W
	73/23/EWG 89/336/EWG

GUARANTEE:

You have purchased a high-quality product that was produced and packaged with the utmost care. Should you nevertheless have grounds for complaint, please contact your retailer quoting the final inspection number as stated on the last page of this document. We will deal with your complaint immediately. This warranty applies only to products that have been fitted appropriately – we therefore recommend fitting by qualified personnel.



FRANÇAIS

- ① Avant tout montage, veuillez vérifier que le luminaire ne présente aucun défaut apparent (p.ex. rayures). Aucune réclamation ne peut être acceptée après montage.
- ② Merci de contacter un spécialiste agréé en électricité pour le montage.
- ③ Veuillez faire attention à la bonne polarité des câbles!
Dans la cas d'une erreur de polarité lors du branchement, veuillez couper le courant avant toute modification! Ceci afin d'éviter d'endommager le luminaire.
- ④ Protection de la surface :
Toutes les surfaces polies, laquées ou galvanisées doivent être protégées des moindres sollicitations mécaniques ou chimiques, en particulier les pièces en cuivre, étant uniquement protégées par un traitement non - visible antioxydant.
- ⑤ Veuillez nettoyer le luminaire uniquement avec un tissu sec. Nous conseillons des tissus micro pour surfaces sensibles. Le nettoyage doit s'effectuer lorsque le luminaire est froid.
- ⑥ Veuillez noter, que lorsque de luminaire est souvent réglé en hauteur, cela peut user les câbles. Ceux-ci doivent être contrôlés de temps en temps.

CHOICE LUMINAIRE OH	
	Classe de protection 3
	Ce produit contient une source lumineuse de classe d'efficacité énergétique G. Les LED intégrés dans le luminaire ne peuvent être remplacés que par le fabricant.
	SEC 500mA / 11W
	73/23/EWG 89/336/EWG





GARANTIE:

Vous venez de faire l'acquisition d'un produit de haute qualité, fabriqué et emballé avec le plus grand soin. Si, malgré le soin apporté, vous êtes amené à rencontrer un problème, merci de contacter exclusivement votre revendeur en indiquant le numéro de contrôle qui se trouve en dernière page. Notre société donnera suite sans tarder à votre réclamation. Vous comprenez aisément que nous ne pouvons assurer de garantie que dans le cas où le montage du matériel a été effectué correctement - par conséquent, nous vous recommandons de vous adresser à un spécialiste.



ITALIANO

- 1 Il prodotto deve essere controllato prima dell'assemblaggio. Difetti visuali/graffi, se riscontrati, devono essere segnalati prima di installare la lampada, altrimenti il cliente non avrà più diritto al reclamo.
- 2 Per favore fate eseguire l'installazione da un elettricista.
- 3 **Attenzione ai poli diversi!**
Se avete invertito erroneamente i poli, prima di effettuare la correzione, togliete la corrente! Eviterete così di danneggiare la lampada.
- 4 **Protezione delle superfici :**
Tutte le superfici trattate con lucidatura, lacca o in bagni galvanici, sono da proteggersi da qualsiasi tipo di sollecito, in particolare quelle in rame, che hanno solo un sottile film contro la colorazione nel tempo.
- 5 Per favore pulire la lampada esclusivamente con un panno asciutto. Si consiglia di utilizzare tessuti in microfibra. Le lampade devono essere fredde durante la pulizia.
- 6 Si fa presente che ripetute regolazioni dell'altezza del lampadario usurano le funicelle. Occorre fare di tanto in tanto un opportuno controllo.

CHOICE LUMINAIRE OH	
	Classe di sicurezza 3
	Questo prodotto contiene una sorgente luminosa di classe di efficienza energetica G. I LEDs possono essere cambiati esclusivamente dal produttore.
	SEC 500mA / 11W
	73/23/EWG 89/336/EWG

GARANZIA:

Avete deciso di acquistare un prodotto d'alto valore, prodotto ed imballato con accuratezza. Se ci fossero ragioni per un reclamo, vi preghiamo di rivolgervi esclusivamente al vostro rivenditore di fiducia. Per favore indicate per chiarezza il numero di controllo stampato sull'ultima pagina. Il vostro reclamo sarà elaborato presso di noi. Considerate che da parte nostra possiamo assumere la garanzia del prodotto soltanto nel caso in cui il montaggio avvenga a regola d'arte: consigliamo dunque di rivolgersi ad aziende d'installazione specializzate.

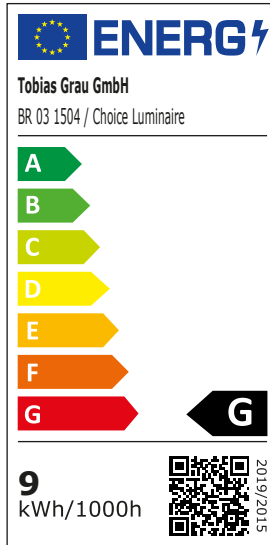

Endkontrollnummer	2 Jahre Garantie 5 Jahre Garantie auf die LED
Final inspection number	2 years guarantee 5 years guarantee of LED
Numéro de contrôle final	2 ans de garantie 5 ans de garantie sur les LED
Numero di controllo finale	2 anni di garanzia 5 anni di garanzia per i LED

